

# RD2000+ RD2000<sup>S</sup> RD2000<sup>CPS</sup> and T1

## User Guide



This User Guide covers the use of the RD2000 receiver and transmitter.

- All variations of the RD2000 receiver
- All variations of the T1 transmitter



### RD2000 Locator features

- 1 On/Off Trigger**  
Press and hold to use RD2000
- 2 Loudspeaker**  
Detachable speaker
- 3 LCD Meter**  
Liquid Crystal Display meter with automatic depth readout
- 4 Sensitivity Control**
- 5 Function Switch**
- 6 Battery compartment**  
To replace batteries, open the access cover using a screwdriver or coin. Use two LR20 or D type alkaline batteries (or equivalent NiMH rechargeable batteries)

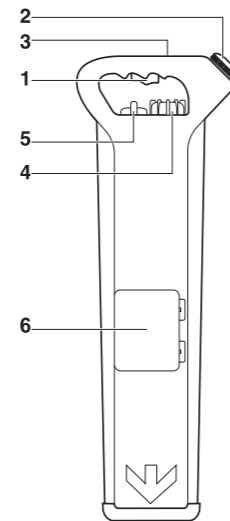

### RD2000 LCD features

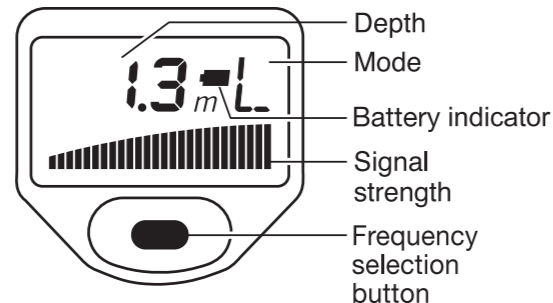

- Depth
- Mode is selected using the function switch (if it is indicated)  
L = Active line mode R = Radio, P = Power, C = CPS(optional), S= Sonde (optional)
- Battery Indicator
- Signal strength as indicated by the bar graph
- Frequency selection button (this button is not used in the RD2000<sup>S</sup> product)

### Depth Measurement

The RD2000 will measure the depth and be automatically displayed in Active Line, Sonde and CPS modes.

Method : Locate the utility as described. Hold the RD2000 still and vertically centred above the detected line.

#### Notes:

A depth measurement will not be displayed where the environmental conditions are poor (e.g weak signal or interference)

The measurement is to the centre of the pipe/conductor or to the centre of the sonde which may rest at the bottom of the pipe.

The measurement accuracy is +/- 5% or better under standard earth conditions. When digging for cables after location, it is imperative that due care is taken commensurate with the danger of personal injury and damage to infrastructure. It is recommended that depth measurement is repeatedly made during a dig.

All modes on the RD2000<sup>S/CPS</sup> are initiated by the trigger - if the batteries are in good condition you will hear an initial "chirp" sound . Poor battery condition is indicated by a flashing battery icon and a lower pitch chirp.

### Power and Radio mode location

#### Please Note

Please Note : After completion of Power mode sweep we recommend that you repeat the procedure with Radio Mode selected (the procedure is the same).

#### Power Mode

For detection of power signals radiated by loaded cables. These are often found "re-radiated" by other nearby conductors. Select "Power" using the function switch. Rotate the sensitivity control fully clockwise for maximum sensitivity but reduce if there is a blanket signal across the site. Define the area to be excavated and carry out a grid pattern sweep.

Sweep holding the RD2000 upright at your side. Continue the sweep beyond the perimeter of the area to be excavated. The presence of a buried conducting pipe or cable will be indicated by a tone emitted from the loudspeaker and the display on the bar graph.

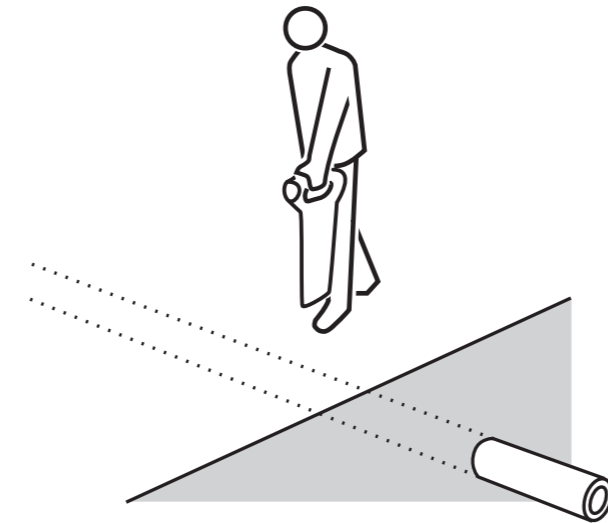

Keep the blade of the RD2000 vertical and move slowly backwards and forwards over the conductor, reducing the sensitivity for a narrower response. With the RD2000 use the meter deflection to aid pinpointing. Maximum meter deflection and audible volume from the speaker will indicate the position of the conductor

When directly over the conductor and with the sensitivity level set for a narrow response, rotate the RD2000 on its axis until the signal minimum is found. The blade is now in line with the conductor.

Trace the conductor out of the area, marking the position as required with chalk or paint.

#### Radio Mode

For detection of radio signals originating from the distant radio transmitters. These penetrate the ground and are re-radiated by buried conductors. However, they are not always present.

#### CPS Mode (RD2000<sup>CPS</sup> only)

The RD2000 has an optional CPS mode enabled instead of the Sonde mode. CPS is a configuration that provides an Active Line Locate using either 100 or 120Hz. CPS mode is used for the detection of pipes with a cathodic protection current.

To enable CPS mode, turn the RD2000<sup>CPS</sup> switch position until "C" is displayed on position 2 on the LCD display.

### T1 - 1W Transmitter

The T1 is a general purpose, 1 Watt, transmitter providing up to three locate frequencies and two power levels. It is the perfect companion to the RD2000 range of cable and pipe locators.

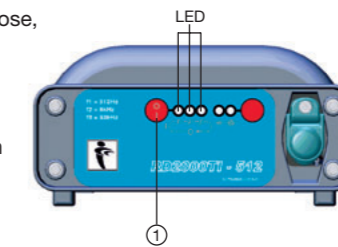

#### Transmitter features

##### 1 On/Off

First press turns the transmitter on and selects the low frequency - 640Hz or 512Hz depending on product specified (not an induction mode). Second press selects 8192Hz. Third press selects 32768Hz. Fourth press turns transmitter off. LEDs indicate which frequency has been selected.

##### 2 Power Select

Selects either high or low power level. LEDs indicate which power level has been selected.

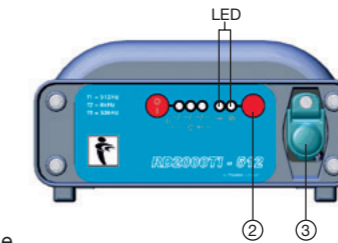

##### 3 Connection Socket

Accepts connection cable or optional accessories such as Signal Clamp, Live Cable Connector or Live Plug Connector. When connected, the induction mode is disabled. A loudspeaker emits a pulsing tone to indicate an a good battery level and a satisfactory direct connection.

##### 4 Batteries Access Panel

No tone indicates that all batteries require replacing. Unscrew fastener and replace 4 x LR20 (D cells) Observe correct battery polarity as indicated on the main label.

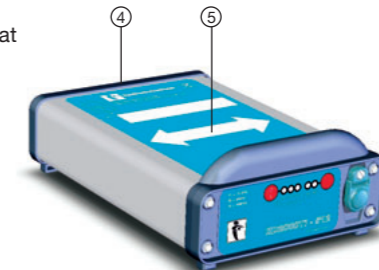

##### 5 Arrows

For signal induction, arrows on the main label indicate the required transmitter alignment above either the pipe or cable.

N.B Turn off the T1 and remove any connection cables before changing batteries

### Trouble Shooting

When reporting any problem to your Radiodetection Dealer/Supplier it is important to quote the unit serial number. When purchased.

#### WARNING!

**This equipment is NOT approved for use in areas where hazardous gases may be present.**

**Reduce audio level before using earpiece.**

**Batteries should be disposed of in accordance with your Company's work practice, and/or the relevant law or guidelines in your country.**

This instrument, or family of instruments, will not be permanently damaged by reasonable electrostatic discharge and has been tested in accordance with IEC 801-2. However, in extreme cases temporary malfunction may occur. If this happens, switch off, wait and switch on again. If the instrument still malfunctions, disconnect the batteries for a few seconds.

**Hereby, Radiodetection, declares that this T1 transmitter is in compliance with the essential requirements and other relevant provisions of Directive 1999/5/EC.**

#### WARNING !

**The RD2000 will detect almost all buried conductors but there are some which do not radiate any signal which the RD2000 or any other magnetic instrument will not detect. There are also some live cables which the RD2000 will not be able to detect in Power mode. The RD2000 does not indicate whether a signal is from a single cable or from several in close proximity.**

## Radiodetection

Radiodetection Ltd, Western Drive, Bristol BS14 0AF, UK  
Tel: +44 (0) 117 976 7776 Fax: +44 (0) 117 976 7775  
email:sales.uk@radiodetection.spx.com

Radiodetection, 154 Portland Road, Bridgton, Maine 04009, USA  
Toll free: 1-877-247-3797 Tel: (207) 647-3185 Fax: (207) 647-9596  
email: bridgton@radiodetection.spx.com

[www.radiodetection.com](http://www.radiodetection.com)

**Service and Maintenance**  
The RD2000 & T1 are designed so that they do not require regular calibration. However, as with all safety equipment, it is recommended that they are serviced at least once a year either at Radiodetection or an approved repair centre.

Radiodetection products are under continuous development and are subject to change without notice.

## Connection Cable

Red cable connects the Transmitter signal directly to target line. Black cable provides the ground return via Ground Stake.

Connect cable plugs lock in place in socket. To unlock cable, grip the black sleeve on the outside of the plug. Do not pull the wire as this may damage the cable and/or socket.

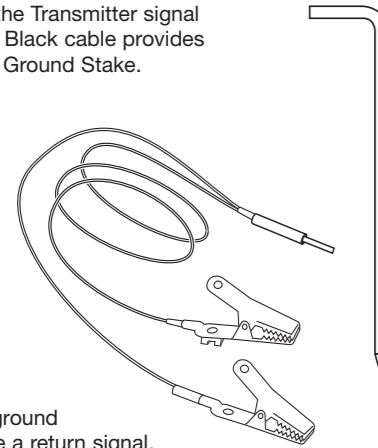

## Ground Stake

This is for making a ground connection to provide a return signal.

Regularly check your RD2000 and T1, in all modes over a cable which gives a response you are familiar with.

## Locating with the RD2000 and T1 transmitter

### Induction

The Transmitter has an internal aerial that will induce a signal onto a line (or lines) directly below it, without the need for access to the line. Generally, induction can only be used to depths of 2m(6ft).

Induction is only available with frequencies 8kHz and above.

### Procedure

Set down the Transmitter over the approximate position of the line with arrows pointing parallel to the line. Set Receiver sensitivity to mid-way and start locating line at least 10 paces away from the Transmitter. Mark the ground where each peak response is detected by the Receiver.

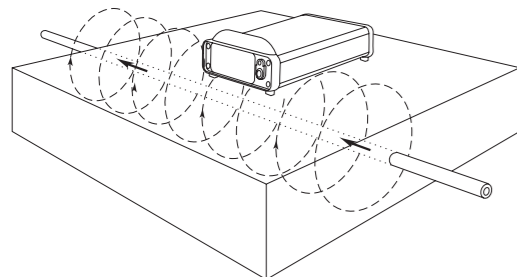

## Note

Induction cannot be used to apply a signal to a line below reinforced concrete. The Transmitter signal may be detected directly and not from the target line, so do not attempt depth measurements when closer than 15 paces from the Transmitter. To check, point the Receiver directly at the transmitter. If the Receiver signal strength increases, either reduce the transmitter power or increase the distance from the transmitter.

If the Receiver signal strength decreases, the received signal is from the buried line.

### Direct Connection

Suitable for use on continuous tracer wire, water and gas distribution systems, a telecom cable, and pipeline at a CP test or other access point.

### Procedure

Plug the Connection Cable into the Transmitter and to the target line. If necessary clean off paint, rust or scale to ensure good connection.

Clip the ground cable to an independent grounding point a few paces away and preferably at right angles to the probable route of the target line. Do not attach ground to water pipe or buried line which could carry the signal.

Start with the low power setting. A good connection is indicated by a change in loudspeaker tone. If there is no tone change, check the electrical contact and ground. If necessary change the position of the ground or tip water over the ground contact if placed in dry soil or sand. If there is still no change in tone increase the power setting to high.

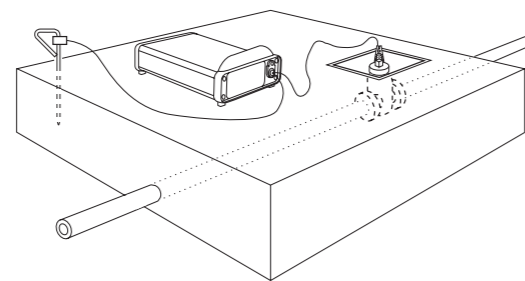

## Note

A Receiver can detect a signal many times weaker than that necessary for a Transmitter tone change and short distances can be traced without a tone change from the loudspeaker.

## WARNING!

**Should only be used on a power cable sheath by qualified personnel.**

### Signal Clamp (optional extra)

The Signal Clamp applies a signal to a pipe or a live cable without interrupting the supply. It applies a very discriminating signal with reduced coupling to other conductors.

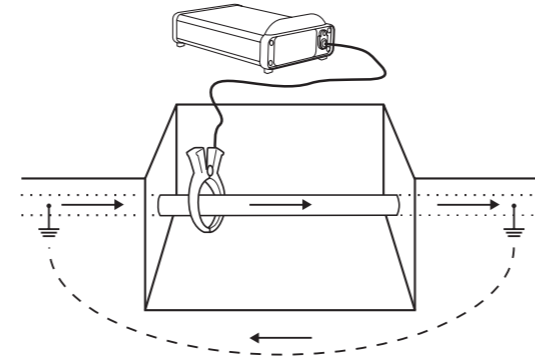

## WARNING!

**To avoid the risk of electric shock, the signal clamp must be connected to the transmitter before being placed around the pipe or cable.**

### Procedure

Connect the Signal Clamp to the Transmitter.

Place the Signal Clamp around the pipe or cable, ensuring the jaws are closed. Switch on the Transmitter.

A disconnected pipe or cable cannot generally be located using a signal clamp.

### Locating a Sonde

A new battery of freshly recharged battery should be used at the beginning of each day and preferably at the start of each job. Check that the sonde and receiver are operating at the same frequency and working correctly.

As a quick test for both Sonde and receiver - position the Sonde at a distance equal to its rated Depth range from the receiver. Point the receiver at the Sonde with its blade in line. Check that the bar graph shows more than 50% at high sensitivity

Note the blade of the new receiver must be in line with the sonde, the opposite to Line locate.

Attach the Sonde to the rod and insert it into the Drain or Duct to be located. Keep the sonde just in view. Hold the receiver vertically directly over the sonde with the blade in line with the sonde.

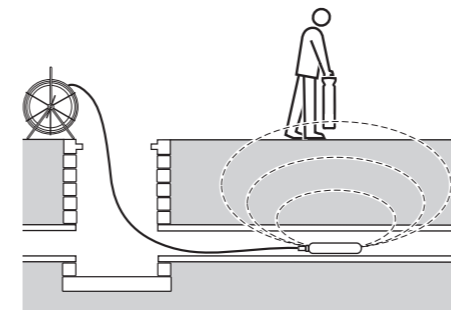

Adjust the sensitivity of the receiver to give a bar graph reading between 60-80%.

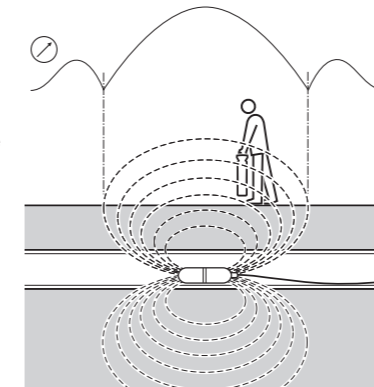

A sonde radiates a peak field from the centre of its axis with ghost signals at each side of the peak. Move the receiver a little way to one side and then along the axis of the Sonde forwards and backwards to detect the ghost signals.

It is a good idea to locate the ghost signals as finding them positively confirms the position of the main peak. To loose the ghost signals reduce the sensitivity of the receiver a little, leaving only the main peak signal detectable.

With the receiver sensitivity set as desired, propel the sonde along three or four paces and stop. Place the receiver over the supposed position of the Sonde and...

(a) move the receivers backwards and forwards with the blade in line with the Sonde and stop when the bar graph indicates a clear peak.

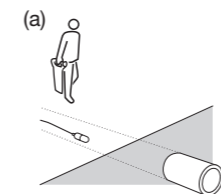

(b) rotate the receiver as if the blade were a pivot, stop when the bar graph indicates a clear peak.

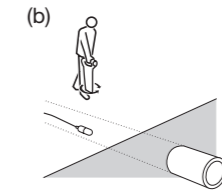

(c) move the receiver from side to side until the bar graph indicates a clear peak.

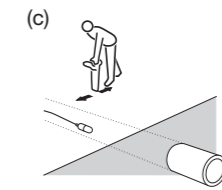

(d) during (c) the depth reading will begin to show up. Observe the depth reading when moving the receiver from side to side, the lowest reading will be the correct location.

Repeat (a), (b) and c in smaller increments with the receiver blade resting on or near the ground. The receiver should now be directly above the Sonde with the blade in line with the Sonde, mark this position.

Propel the sonde a further three to four paces along the drain or duct and pinpoint and mark. Repeat the procedure along the route at similar intervals. It should only be necessary to change the receiver sensitivity while tracing the Sonde if the depth of the drain or duct, or the distance between receiver and Sonde changes.

## Measuring depth to a Sonde

Pinpoint the sonde as previously described and rest the receiver on the ground and in line with the sonde. Adjust the sensitivity to give a meter reading of 60% to 80%.

Remember the depth reading is from the bottom of the receiver blade to the centre of the Sonde and not to the drain or duct being located.

**CAUTION: Ensure Depth readings are taken at the main peak readings, a depth reading taken at the ghost signal position will be incorrect.**

Depth measurement is automatic. Depth reading will be displayed when the receiver is moved slowly across the Sonde. The shallowest depth reading displayed on the LCD is also the correct position directly above the Sonde (always ensure you always follow steps a - d).

If the signal is too weak or unstable the receiver unit will not calculate depth. In this case use a more powerful Sonde and proceed as instructed above.

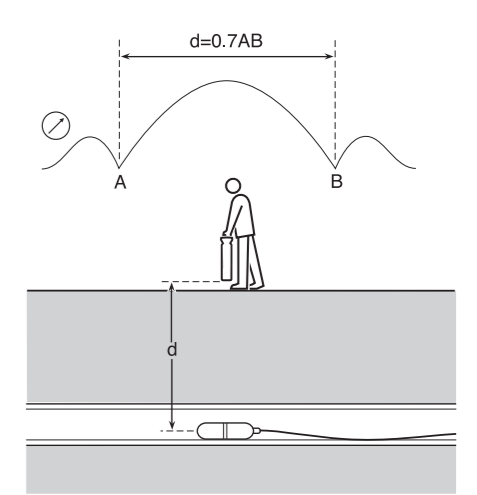

Pinpoint the sonde. Move the receiver in front of the Sonde still in line with it, increasing the sensitivity slightly to find the ghost signal. Between the main peak and ghost there is a Null or minimum, mark this position for reference. Now move behind the Sonde and repeat, find the null between the ghost and main peak. See points "A" and "B" on the diagram. The higher the sensitivity of the receiver the sharper the Null's appear.

Measure the distance between points "A" and "B" and multiply by 0.7 to give an approximate depth measurement.

### Live Plug Connector (optional extra)

Applies the Transmitter signal to a live domestic power socket and via the domestic wiring system on the service cable and the supply cable in the street. The signal should be detectable on the supply system to a few hundred paces each side of the point of application.

### Note

Do not connect the Transmitter to live cables without using a Plug Connector or Live Cable.

### Procedure

Connect the Live Plug Connector to the Transmitter and to the live domestic power socket. Switch on the socket.

### Note

Live Plug Connector contains a protection unit to protect the user and the Transmitter from mains voltage up to 250V.